

CAD FILE:

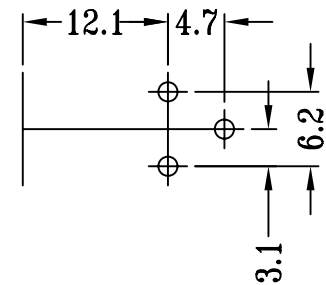

P.C.B LAYOUT

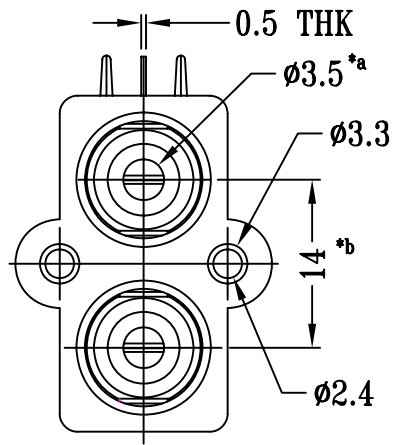
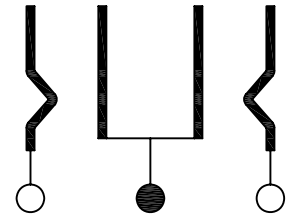
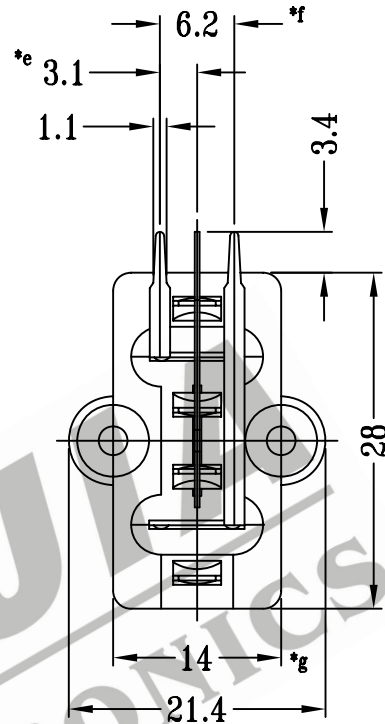
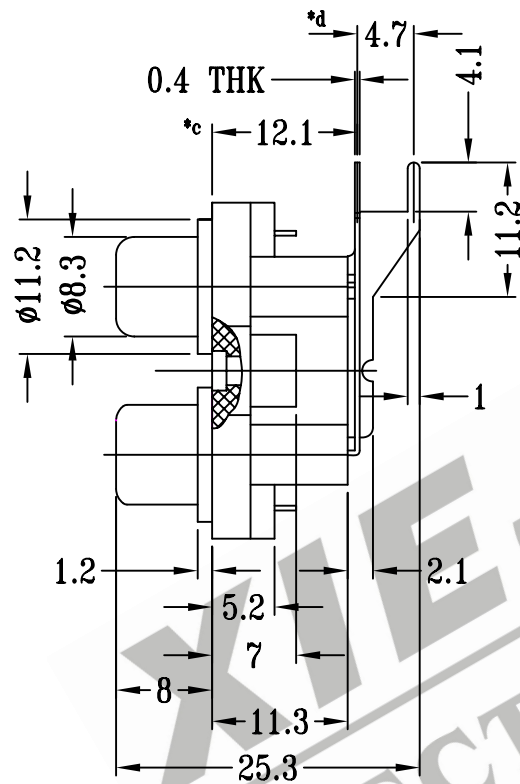

SCHEMATIC

MODEL NO.	X COLOR.	Y COLOR.
RC-216-BB	BLACK	BLACK
RC-216-BW	BLACK	WHITE
RC-216-BR	BLACK	RED
RC-216-BY	BLACK	YELLOW
RC-216-WB	WHITE	BLACK
RC-216-WW	WHITE	WHITE
RC-216-WR	WHITE	RED
RC-216-WY	WHITE	YELLOW
RC-216-RB	RED	BLACK
RC-216-RW	RED	WHITE
RC-216-RR	RED	RED
RC-216-RY	RED	YELLOW
RC-216-YB	YELLOW	BLACK
RC-216-YW	YELLOW	WHITE
RC-216-YR	YELLOW	RED
RC-216-YY	YELLOW	YELLOW

注:带"*"表示关键尺寸(7个)

NO.	PART NAME	MATERIAL	Q'TY	FINISHING	TOLERANCE UNLESS SPECIFIED	SHENZHEN XIEJIA ELECTRONICS CO.,LTD.				
8						TITLE : RCA JACK MODEL: RC-216-BB				
7										UNIT : MM
6	SLEEVE	BRASS	2	Ni PLATED	WITHIN: 1.5±0.1mm OVER : 1.5±0.2mm	ISSUE	DATE	DESCRIPTIONS		APPD.
5	WASHER	PC	2	BLACK/WHITE/RED/YELLOW				DWN.	ZHOUYU	2003-9-19
4	CASE	ABS	1	BLACK				CHK'D	FANGYING	2003-9-19
3	TERMINAL C	BRASS STRIP	1	Ag PLATED OVER Ni PLATED				APPD.	KANGXINAN	2003-9-19
2	TERMINAL B	BRASS STRIP	1	Ag PLATED OVER Ni PLATED				ALL MATERIALS MUST BE COMPLIANT TO ROHS		
1	TERMINAL A	BRASS STRIP	1	Ag PLATED OVER Ni PLATED						